

1 2 3 4 5 6 7 8

REVISIONS		
ISS	ZONE	DESCRIPTION\PER REQUEST\DATE

業務部

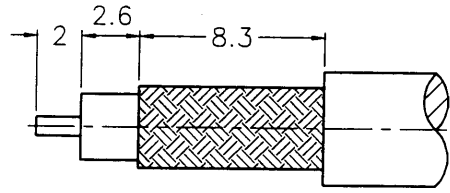

RECOMMENDED
CABLE STRIPPING DIM'S
(建議剝線尺寸)

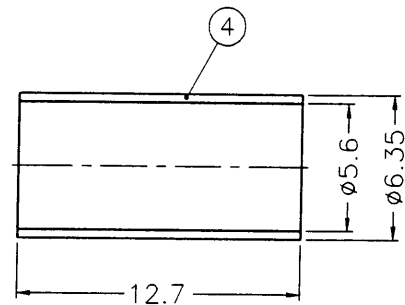
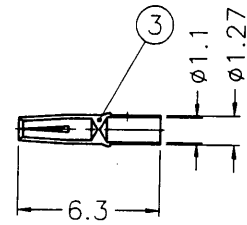
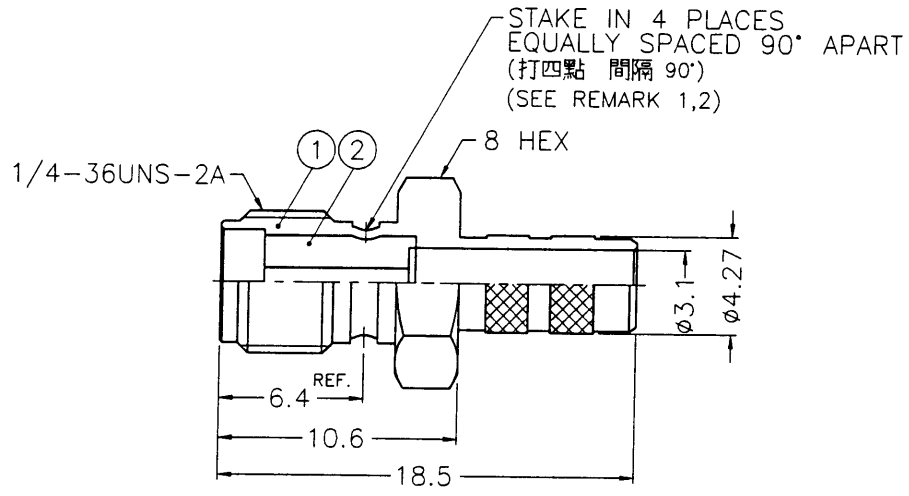

1. CRIMPED FERRULE
HEX CRIMP SIZE .213"
2. CONTACT PIN TO SOLDER

- NOTES: FINISH (PLATING THICKNESS IN MICRO-INCHES)
1. BRASS PER QQ-B-626
 2. GOLD PL. 3 MIN. THICK OVER NICKEL PL. 100 MIN. THICK OVER COPPER STRIKE
 3. BERYLLIUM COPPER PER QQ-C-530
 4. GOLD PL. 50 MIN. THICK OVER NICKEL PL. 100 MIN. THICK OVER COPPER STRIKE
 5. TEFLON MIL-P-19468
 6. JIS H 3250, C 2700

- REMARK: 1. NO.2 MUST WITHSTAND A 6 lbs. MIN. PUSHOUT FORCE FROM NO.1 AFTER STAKING OPERATION
2. REMARK1 IS MAINTAINED BY STAMPING THE FOUR POINTS SHOWN ON THE DRAWING WITHOUT PUNCTURING NO.1
- (1. 打四點後零件 2 由零件 1 推出至少必須承受 6 磅推力)
(2. 打四點後除需符合備註 1 要求外 且不可擊穿零件 1)



DIMENSIONS ARE IN MILLIMETERS						PART NO.		Amphenol - Kai Jack	
UNLESS OTHERWISE SPECIFIED TOLERANCES						APPROVED		TAINAN TAIWAN	
4	FERRULE	NOTE 6	NOTE 2	1	FR-635/56X127	DATE 08-09-00'		TITLE SMA CRIMP JACK (FOR RG-55/U,142A/U,223/U,400/U)	
3	CONTACT PIN	NOTE 3	NOTE 4	1	SMA6511B3-3-127/11	DATE 08-09-00'		DRAWING NO. KJ-SMA6111A3-3GT50G-223U-50	
2	INSULATOR	NOTE 5	NATURAL	1	SMA6511B3-2T-58U	DATE 08-09-00'		FILE NO. F:\DWG\SMA\6111A3\223U-50\3GT50G	
1	BODY	NOTE 1	NOTE 2	1	SMA6111A3-1-427/31	DATE 08-09-00'			
NO.	DESCRIPTION	MATERIAL	FINISH	Q'TY	DRAWING NO.	SCALE	3/1	ISSUE	A

APPROVED: [Signature] DATE 08-09-00'
CHECKED: [Signature] DATE 08-09-00'
DRAWN: [Signature] DATE 08-09-00'

F
E
D
C
B
A

F
E
D
C
B
A

1 2 3 4 5 6 7 8