

RECOMMENDED MOUNTING HOLE
 MAXIMUM PANEL THICKNESS: 5.5MM
 RECOMMENDED MOUNTING TORQUE:
 12 INCH-POUNDS MAX

FINISH

BODY-----NICKEL PLATING
 CENTER CONTACT-----GOLD PLATING
 SOLDER TAIL-----TIN LEAD PLATING
 MOUNTING POST-----TIN LEAD PLATING
 WASHER-----NICKEL PLATING
 NUT-----NICKEL PLATING

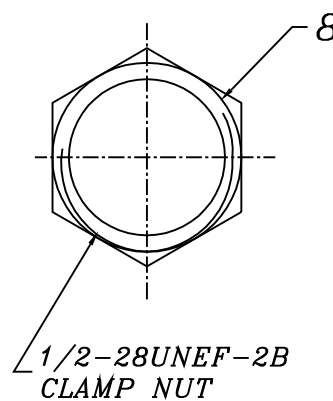
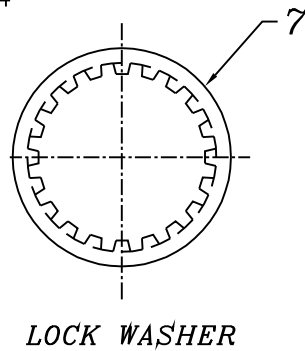

CONSTRUCTION

- ① CENTER CONTACT(JACK)--PHOSPHOR BRONZE
- ② CENTER CONTACT(PLUG)--PHOSPHOR BRONZE
- ③ BODY-----ZINC ALLOY
- ④ DIELECTRIC-----PE-606
- ⑤ MOUNTING POST---BRASS
- ⑥ SOLDER TAIL-----BRASS WIRE
- ⑦ WASHER-----PHOSPHOR BRONZE
- ⑧ NUT-----BRASS

易昕企業有限公司 LEAMAX ENTERPRISE CO., LED.		
PROJ	SCALE : F DO NOT SCALE DWG	MOLD NO 3281
APP		MODEL
CHK	CCJ	89.11.01
DGN	WU	89.11.01
DRW	SHIEH	89.11.01
	UNIT MM	FILE NO
		SHT 1 OF 1
		REV. X1
		SIZE A4