

RoHS
Compliant
2002/95/EC

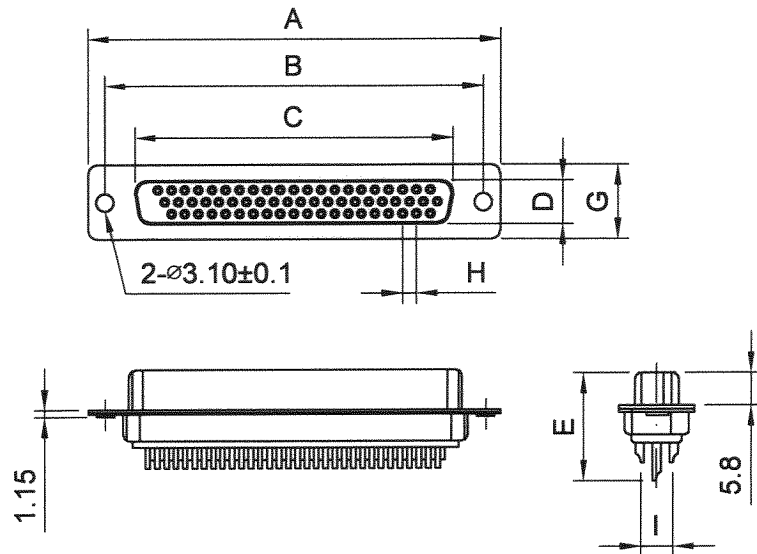

NOTE:

1.MATERIAL:

- 1.1 INSULATOR : HIGH TEMPERATURE THERMOPLASTIC WITH G.F.U.L94V-0
- 1.2 CONTAC : COPPER ALLOY, T=0.20mm
- 1.3 SHELL : SPCC, T=0.30mm

2.SPECIFICATION:

- 2.1 CURRENT RATING : 1 A MAX.
- 2.2 DIELECTRIC WITHSTANDING VOLTAGE : 750 V(AC) FOR 1 MIN.
- 2.3 CONTACT RESISTANCE : 30 mΩ MAX.
- 2.4 INSULATION RESISTANCE : 1000 MΩ MIN.
- 2.5 TOTAL MATING FORCE : 8.0 kgf MAX.
- 2.6 TOTAL UNMATING FORCE : 1.5 kgf MIN.
- 2.7 TEMPERATURE RANGE : -25°C ~ +85°C

DBL3XxxFGFAxV00

- U : BLUE PLASTIC
- Q : BLACK PLASTIC
- S : WHITE PLASTIC
- NO. OF CONTACTS
- A : 全通孔
- B : 前鍍銅柱 (不通孔)
- C : 後鍍銅柱 (通孔)

A	全通孔	B	前鍍型 (不通孔)	C	後鍍型 (通孔)

PART NO.	A±0.25	B±0.20	C±0.20	D±0.20	E±0.30	G±0.25	H±0.05	I±0.10
15F	30.81	24.99	16.33	8.00	16.50	12.55	2.29	3.96
26F	39.25	33.32	24.66	8.00	16.50	12.55	2.29	3.96
44F	53.04	47.04	38.38	8.00	16.50	12.55	2.29	3.96
62F	69.50	63.50	54.84	8.00	16.50	12.55	2.29	3.96

JAWS 兆旭股份有限公司
JAWS CO., LTD.

7F-1, NO.31, Lane 169, Kang Ning Street,
Hsichih, Taipei Hsien, Taiwan.
TEL: 886-2-2692-2898
FAX: 886-2-2692-2618
Http://www.jaws.com.tw

THIRD ANGLE
PROJECTION

DESIGN UNITS
mm INCH

TITLE:

D-SUB HDD SOLDER FEMALE

GENERAL TOLERANCES:

±0.30

DRAWN

游熾瑩

DATE 97/05/22

SIZE:

A4

SCALE:

FREE

SHEET:

1/1

PARTS NO.:

DBL3XxxFGFAxV00

±0.30

CHECK

郭中男

DATE 97.5.22

CPN NO.:

DAN NO.: S9705-032

DWG NO.:

JAWS-SOP-DBL3X001

REV.

02

APPROVE

陳世官

DATE 97.5.26