

RoHS
Compliant
2002/95/EC

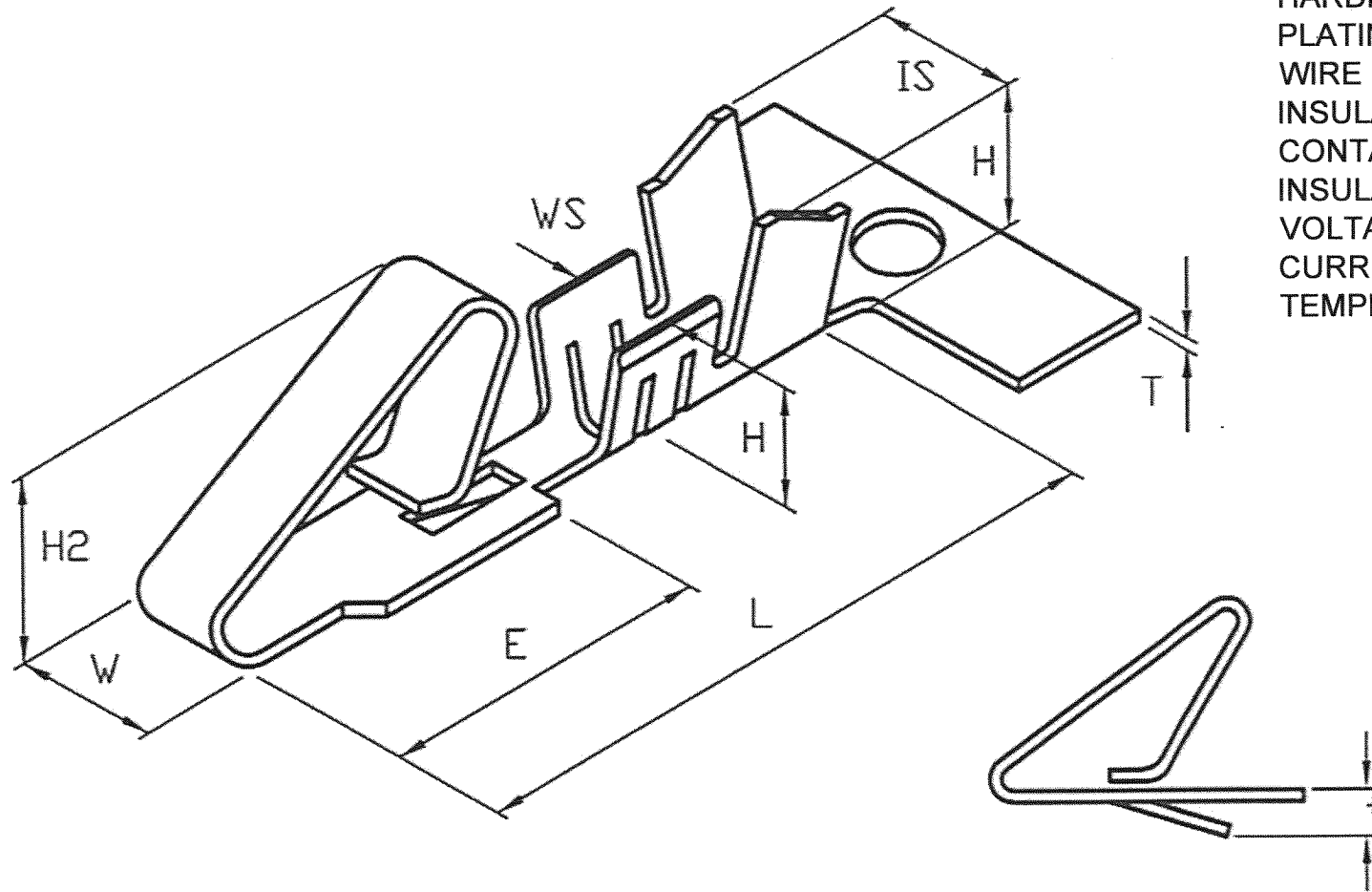

SPECIFICATIONS

MATERIAL : BRASS

THICKNESS : 0.25

HARDNESS : SH

PLATING : TIN 40 μ " MIN.

WIRE RANGE : 18-24AWG

INSULATION O.D. : 2.8 MAX.

CONTACT RESISTANCE : 10 m Ω MAX.

INSULATION RESISTANCE : 1000 M Ω MIN.

VOLTAGE RATING : AC, DC, 250V

CURRENT RATING : AC, DC, 10A

TEMPERATURE RANGE : -25 $^{\circ}$ C TO +85 $^{\circ}$ C

DIMENSION (mm) :

T = 0.25 \pm 0.03

L = 13.7 \pm 0.3

E = 6.8 \pm 0.25

W = 1.8 \pm 0.15

W1 = 2.7 \pm 0.15

IS = 3.5 \pm 0.25

WS = 2.6 \pm 0.25

H = 3.5 \pm 0.25

H1 = 2.6 \pm 0.25

H2 = 4.5 \pm 0.3

t = 1.0 \pm 0.25

JAWS 兆旭股份有限公司
JAWS CO., LTD.

7F-1, NO.31, Lane 169, Kang Ning Street,
Hsichih, Taipei Hsien, Taiwan.
TEL: 886-2-2692-2898
FAX: 886-2-2692-2618
Http://www.jaws.com.tw

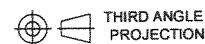

THIRD ANGLE
PROJECTION

DESIGN UNITS
mm INCH

SIZE: A4
SCALE: FREE
SHEET: 1/1

CPN NO.:
DAN NO.: S9710-047

TITLE:
3.96mm TERMINAL

PARTS NO.:
396A-T-TB

DWG NO.:
JAWS-SOP-396A002

REV.
01

GENERAL TOLERANCES :

X. \pm N/A

XX \pm N/A

X.XX \pm N/A

ANGLE \pm N/A

DRAWN	游熾瑩	DATE	97/10/31
CHECK	Lang	DATE	97/10/31
APPROVE	陳世程	DATE	97.11.3