

**RoHS**  
Compliant  
2002/95/EC

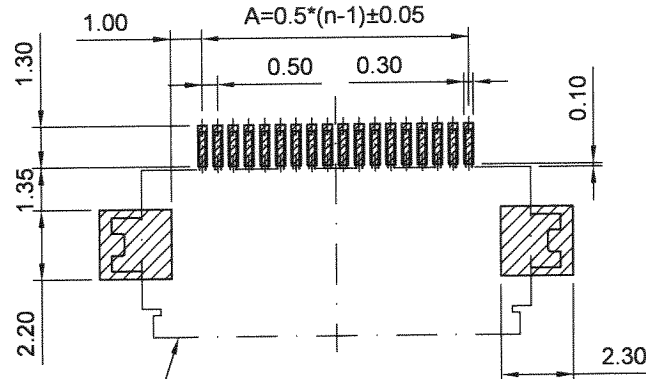
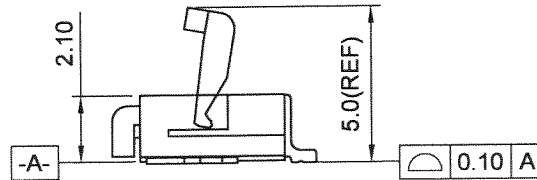
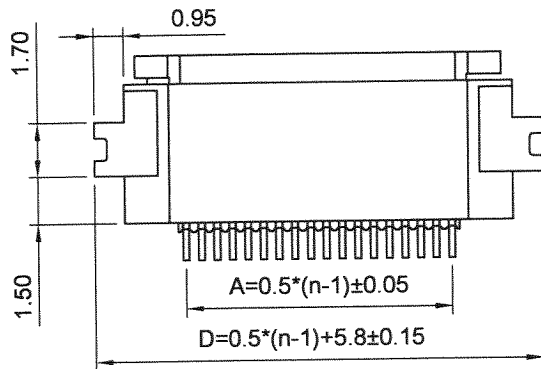
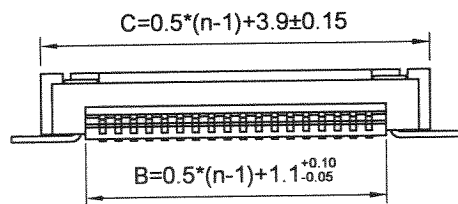
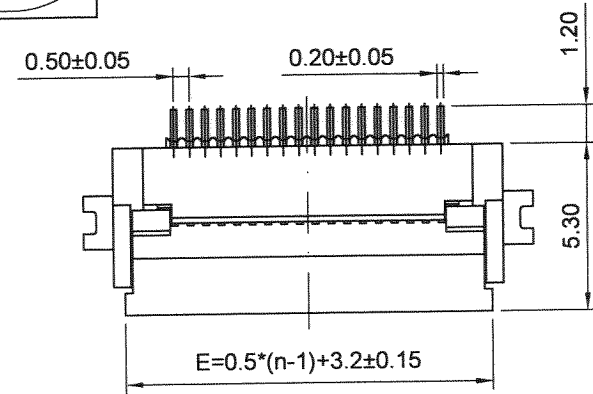

Connector outline  
Recommended PCB layout  
component side

**MATERIAL**

HOUSING : PA46, UL 94V-0, COLOR : NATURAL.  
COVER : PA9T, UL 94V-0, COLOR : BLACK.  
CONTACT : PHOSPHOR BRONZE.  
PLATING : TIN, LEAD FREE, OR ALL GOLD.  
HOLDDOWN : BRASS, PLATING : ALL TIN, LEAD FREE, OR ALL GOLD.

**ELECTRICAL**

VOLTAGE : 50V MAX.  
CURRENT : 0.4A MAX.  
DIELECTRIC WITHSTANDING VOLTAGE : 250 VAC.  
INSULATION RESISTANCE : 50 MΩ MIN.  
CONTACT RESISTANCE : 20 mΩ MAX.

**ENVIRONMENTAL**

TEMPERATURE RANGE : -20°C TO +85°C

**FEATURE AND SPECIFICATIONS**

SIZES 04 TO 50 PIN.  
FOR 0.3mm THICKNESS FFC/FPC.

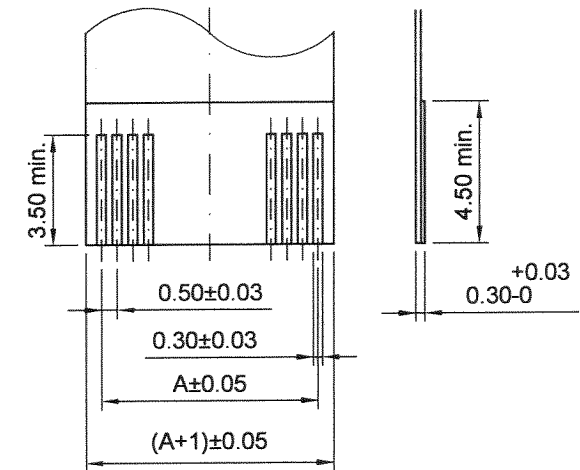

Applicable FPC/FFC  
recommended dimension

**JAWS** 兆旭股份有限公司  
JAWS CO., LTD.

7F-1, NO.31, Lane 169, Kang Ning Street,  
Hsichih, Taipei Hsien, Taiwan.  
TEL: 886-2-2692-2898  
FAX: 886-2-2692-2618  
Http://www.jaws.com.tw

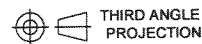

DESIGN UNITS  
mm INCH

TITLE: FFC/FPC 0.5 PITCH CONNECTOR  
ZIF SMT TYPE, BODY HIGH 2.0 mm.

GENERAL TOLERANCES:

±0.30

SIZE: A4      SCALE: FREE      SHEET: 1/2

PARTS NO.: FP4ZUAXXTT1R

DRAWN 游熾瑩      DATE 97/09/09

CHECK 郭峰峰      DATE 97.9.10





APPROVE 陳世官      DATE 97.9.11

CPN NO.:  
DAN NO.: S9709-013

DWG NO.: JAWS-SOP-FP4Z003  
REV. 01

Pin	Part Number	Dimension					Pin	Part Number	Dimension				
		A	B	C	D	E			A	B	C	D	E
* 4	FP4ZUA04TT1R	1.50	2.60	5.40	7.30	4.70	* 28	FP4ZUA28TT1R	13.50	14.60	17.40	19.30	16.70
5	FP4ZUA05TT1R	2.00	3.10	5.90	7.80	5.20	29	FP4ZUA29TT1R	14.00	15.10	17.90	19.80	17.20
* 6	FP4ZUA06TT1R	2.50	3.60	6.40	8.30	5.70	* 30	FP4ZUA30TT1R	14.50	15.60	18.40	20.30	17.70
7	FP4ZUA07TT1R	3.00	4.10	6.90	8.80	6.20	31	FP4ZUA31TT1R	15.00	16.10	18.90	20.80	18.20
* 8	FP4ZUA08TT1R	3.50	4.60	7.40	9.30	6.70	* 32	FP4ZUA32TT1R	15.50	16.60	19.40	21.30	18.70
* 9	FP4ZUA09TT1R	4.00	5.10	7.90	9.80	7.20	* 33	FP4ZUA33TT1R	16.00	17.10	19.90	21.80	19.20
* 10	FP4ZUA10TT1R	4.50	5.60	8.40	10.30	7.70	* 34	FP4ZUA34TT1R	16.50	17.60	20.40	22.30	19.70
11	FP4ZUA11TT1R	5.00	6.10	8.90	10.80	8.20	* 35	FP4ZUA35TT1R	17.00	18.10	20.90	22.80	20.20
* 12	FP4ZUA12TT1R	5.50	6.60	9.40	11.30	8.70	* 36	FP4ZUA36TT1R	17.50	18.60	21.40	23.30	20.70
13	FP4ZUA13TT1R	6.00	7.10	9.90	11.80	9.20	37	FP4ZUA37TT1R	18.00	19.10	21.90	23.80	21.20
* 14	FP4ZUA14TT1R	6.50	7.60	10.40	12.30	9.70	38	FP4ZUA38TT1R	18.50	19.60	22.40	24.30	21.70
* 15	FP4ZUA15TT1R	7.00	8.10	10.90	12.80	10.20	39	FP4ZUA39TT1R	19.00	20.10	22.90	24.80	22.20
16	FP4ZUA16TT1R	7.50	8.60	11.40	12.30	10.70	* 40	FP4ZUA40TT1R	19.50	20.60	23.40	25.30	22.70
* 17	FP4ZUA17TT1R	8.00	9.10	11.90	13.80	11.20	41	FP4ZUA41TT1R	20.00	21.10	23.90	25.80	23.20
* 18	FP4ZUA18TT1R	8.50	9.60	12.40	14.30	11.70	42	FP4ZUA42TT1R	20.50	21.60	24.40	26.30	23.70
* 19	FP4ZUA19TT1R	9.00	10.10	12.90	14.80	12.20	43	FP4ZUA43TT1R	21.00	22.10	24.90	26.80	24.20
* 20	FP4ZUA20TT1R	9.50	10.60	13.40	15.30	12.70	44	FP4ZUA44TT1R	21.50	22.60	25.40	27.30	24.70
* 21	FP4ZUA21TT1R	10.00	11.10	13.90	15.80	13.20	* 45	FP4ZUA45TT1R	22.00	23.10	25.90	27.80	25.20
22	FP4ZUA22TT1R	10.50	11.60	14.40	16.30	13.70	46	FP4ZUA46TT1R	22.50	23.60	26.40	28.30	25.70
23	FP4ZUA23TT1R	11.00	12.10	14.90	16.80	14.20	47	FP4ZUA47TT1R	23.00	24.10	26.90	28.80	26.20
* 24	FP4ZUA24TT1R	11.50	12.60	15.40	17.30	14.70	48	FP4ZUA48TT1R	23.50	24.60	27.40	29.30	26.70
* 25	FP4ZUA25TT1R	12.00	13.10	15.90	17.80	15.20	49	FP4ZUA49TT1R	24.00	25.10	27.90	29.80	27.20
* 26	FP4ZUA26TT1R	12.50	13.60	16.40	18.30	15.70	* 50	FP4ZUA50TT1R	24.50	25.60	28.40	30.30	27.70
27	FP4ZUA27TT1R	13.00	14.10	16.90	18.80	16.20							

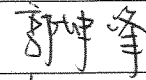
註：“\*”表示已開模規格

 <b>兆旭股份有限公司</b> <b>JAWS CO., LTD.</b> 7F-1, NO.31, Lane 169, Kang Ning Street, Hsichih, Taipei Hsien, Taiwan. TEL: 886-2-2692-2898 FAX: 886-2-2692-2618 Http://www.jaws.com.tw	 THIRD ANGLE PROJECTION	DESIGN UNITS <input checked="" type="checkbox"/> mm <input type="checkbox"/> INCH	TITLE: FFC/FPC 0.5 PITCH CONNECTOR ZIF SMT TYPE, BODY HIGH 2.0 mm.	GENERAL TOLERANCES: <b>±0.30</b>	DRAWN 游熾瑩	DATE 97/09/09		
	SIZE: <b>A4</b>	SCALE: <b>FREE</b>	SHEET: <b>2/2</b>	PARTS NO.: <b>FP4ZUAxxTT1R</b>	CHECK 	DATE 97.9.10		
	CPN NO.:			DWG NO.: <b>JAWS-SOP-FP4Z003</b>		REV. <b>01</b>	APPROVE 	DATE 97.9.11
	DAN NO.: S9709-013							