

RECOMMENDED PCB LAYOUT

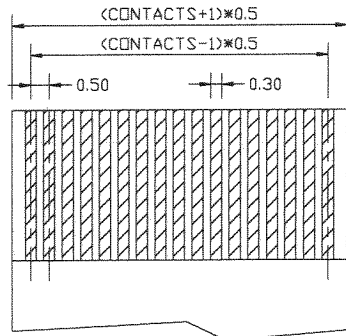

FFC/FPC DIMENSION
THICKNESS 0.30 mm

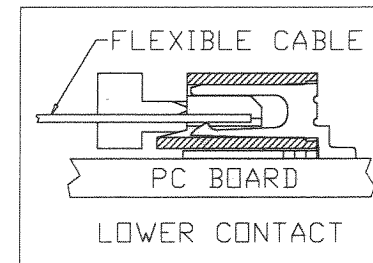
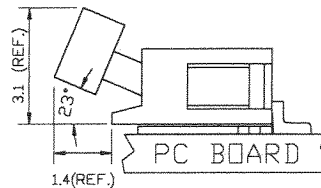
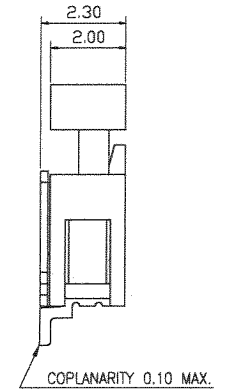
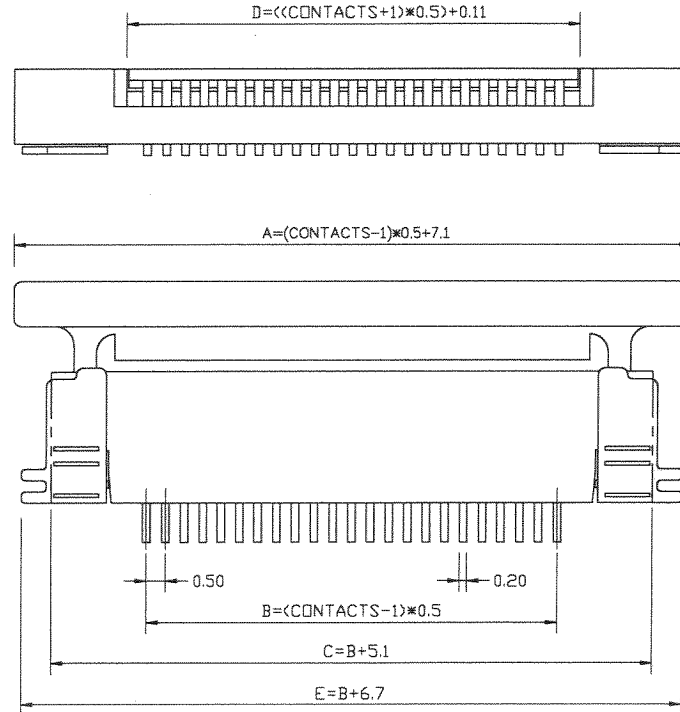
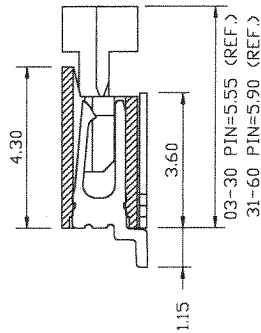

JAWS 兆旭股份有限公司
JAWS CO., LTD.
7F-1, NO.31, Lane 169, Kang Ning Street,
Hsichih, Taipei Hsien, Taiwan.
TEL: 886-2-2692-2898
FAX: 886-2-2692-2618
Http://www.jaws.com.tw

THIRD ANGLE PROJECTION		DESIGN UNITS mm INCH
SIZE: A4	SCALE: FREE	SHEET: 1/2
CPN NO.:		DWG NO.:
DAN NO.: S9610-042		

TITLE: 0.5mm FPC ZIF SMT 下接 90°	
PARTS NO.: FP4ZLBxxTT0T	
DWG NO.:	REV.:
JAWS-SOP-FP4Z002	03

GENERAL TOLERANCES:	
X.X	±0.30
X.XX	±0.25
X.XXX	±0.20
ANGLE	±N/A

DRAWN	游熾瑩	DATE	96/10/22
CHECK	游熾瑩	DATE	96/10/22
APPROVE	陳世官	DATE	96.10.23

RoHS
Compliant
2002/95/EC

PIN	A	B	C	D	E
3	8.10	1.00	6.10	2.11	7.70
4	8.60	1.50	6.60	2.61	8.20
5	9.10	2.00	7.10	3.11	8.70
6	9.60	2.50	7.60	3.61	9.20
7	10.10	3.00	8.10	4.11	9.70
8	10.60	3.50	8.60	4.61	10.20
9	11.10	4.00	9.10	5.11	10.70
10	11.60	4.50	9.60	5.61	11.20
11	12.10	5.00	10.10	6.11	11.70
12	12.60	5.50	10.60	6.61	12.20
13	13.10	6.00	11.10	7.11	12.70
14	13.60	6.50	11.60	7.61	13.20
15	14.10	7.00	12.10	8.11	13.70
16	14.60	7.50	12.60	8.61	14.20
17	15.10	8.00	13.10	9.11	14.70
18	15.60	8.50	13.60	9.61	15.20
19	16.10	9.00	14.10	10.11	15.70
20	16.60	9.50	14.60	10.61	16.20
21	17.10	10.00	15.10	11.11	16.70
22	17.60	10.50	15.60	11.61	17.20
23	18.10	11.00	16.10	12.11	17.70
24	18.60	11.50	16.60	12.61	18.20
25	19.10	12.00	17.10	13.11	18.70
26	19.60	12.50	17.60	13.61	19.20
27	20.10	13.00	18.10	14.11	19.70
28	20.60	13.50	18.60	14.61	20.20
29	21.10	14.00	19.10	15.11	20.70
30	21.60	14.50	19.60	15.61	21.20
31	22.10	15.00	20.10	16.11	21.70

PIN	A	B	C	D	E
32	22.60	15.50	20.60	16.61	22.20
33	23.10	16.00	21.10	17.11	22.70
34	23.60	16.50	21.60	17.61	23.20
35	24.10	17.00	22.10	18.11	23.70
36	24.60	17.50	22.60	18.61	24.20
37	25.10	18.00	23.10	19.11	24.70
38	25.60	18.50	23.60	19.61	25.20
39	26.10	19.00	24.10	20.11	25.70
40	26.60	19.50	24.60	20.61	26.20
41	27.10	20.00	25.10	21.11	26.70
42	27.60	20.50	25.60	21.61	27.20
43	28.10	21.00	26.10	22.11	27.70
44	28.60	21.50	26.60	22.61	28.20
45	29.10	22.00	27.10	23.11	28.70
46	29.60	22.50	27.60	23.61	29.20
47	30.10	23.00	28.10	24.11	29.70
48	30.60	23.50	28.60	24.61	30.20
49	31.10	24.00	29.10	25.11	30.70
50	31.60	24.50	29.60	25.61	31.20
51	32.10	25.00	30.10	26.11	31.70
52	32.60	25.50	30.60	26.61	32.20
53	33.10	26.00	31.10	27.11	32.70
54	33.60	26.50	31.60	27.61	33.20
55	34.10	27.00	32.10	28.11	33.70
56	34.60	27.50	32.60	28.61	34.20
57	35.10	28.00	33.10	29.11	34.70
58	35.60	28.50	33.60	29.61	35.20
59	36.10	29.00	34.10	30.11	35.70
60	36.60	29.50	34.60	30.61	36.20

JAWS 兆旭股份有限公司
JAWS CO., LTD.

7F-1, NO.31, Lane 169, Kang Ning Street,
Hsichih, Taipei Hsien, Taiwan.
TEL: 886-2-2692-2898
FAX: 886-2-2692-2618
Http://www.jaws.com.tw



THIRD ANGLE
PROJECTION

DESIGN UNITS

mm INCH

TITLE:

0.5mm FPC ZIF SMT 下接 90°

GENERAL TOLERANCES:

X. ±0.30

X.X ±0.25

X.XX ±0.20

ANGLE ±N/A

DRAWN

游熾瑩

DATE 96/10/22

CHECK

郭世峰

DATE 96/10/22

APPROVE

陳世官

DATE 96.10.23

SIZE:

A4

SCALE:

FREE

SHEET:

2/2

PARTS NO.:

FP4ZLBxxTT0T

DWG NO.:

JAWS-SOP-FP4Z002

REV.

03