

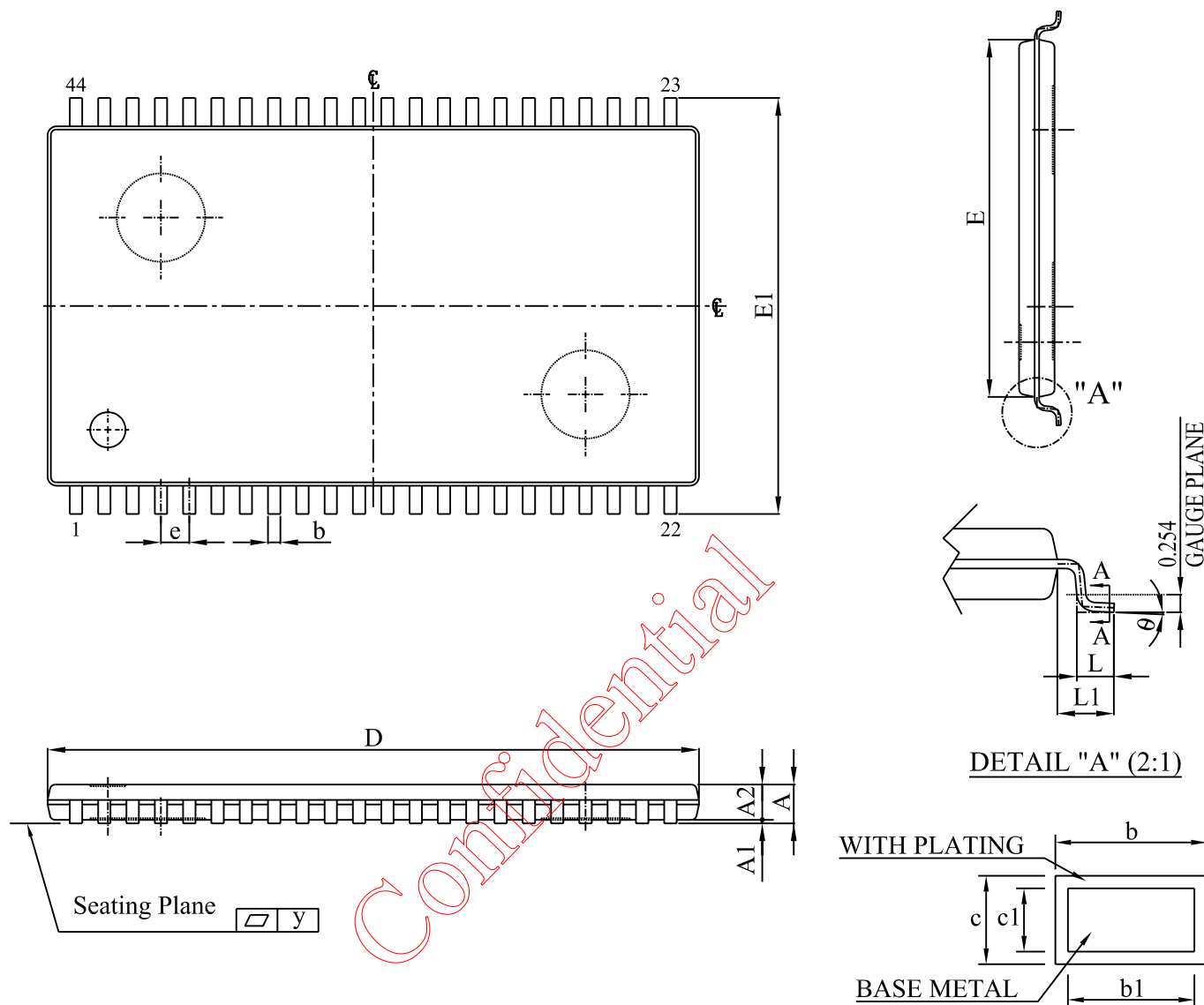

Title: Package outline for 44L TSOP(II)-400mil



Note: Plating thickness spec : 0.3 mil ~ 0.8 mil.

SYMBOL UNIT		A	A1	A2	b	b1	c	c1	D	E	E1	e	L	L1	y	θ
	mm	Min.	1.00	0.05	0.95	0.30	0.30	0.12	0.12	18.31	10.06	11.56	0.70	0.40	0.70	-
Nom.		1.10	0.10	1.00	-	-	-	-	18.41	10.16	11.76	0.80	0.50	0.80	-	-
Max.		1.20	0.15	1.05	0.45	0.40	0.21	0.16	18.51	10.26	11.96	0.90	0.60	0.90	0.1	8°
inch	Min.	0.0393	0.002	0.037	0.012	0.012	0.005	0.005	0.721	0.396	0.455	0.0275	0.0157	0.0275	-	0°
	Nom.	0.0433	0.004	0.039	-	-	-	-	0.725	0.400	0.463	0.0315	0.0197	0.0315	-	-
	Max.	0.0473	0.006	0.041	0.018	0.016	0.008	0.006	0.729	0.404	0.471	0.0355	0.0237	0.0355	0.004	8°

DWG. NO.	ORIGINATOR	ISSUE DATE	REV.
PC600-0006	YUKI_YEH	26-Dec.-'07	1