

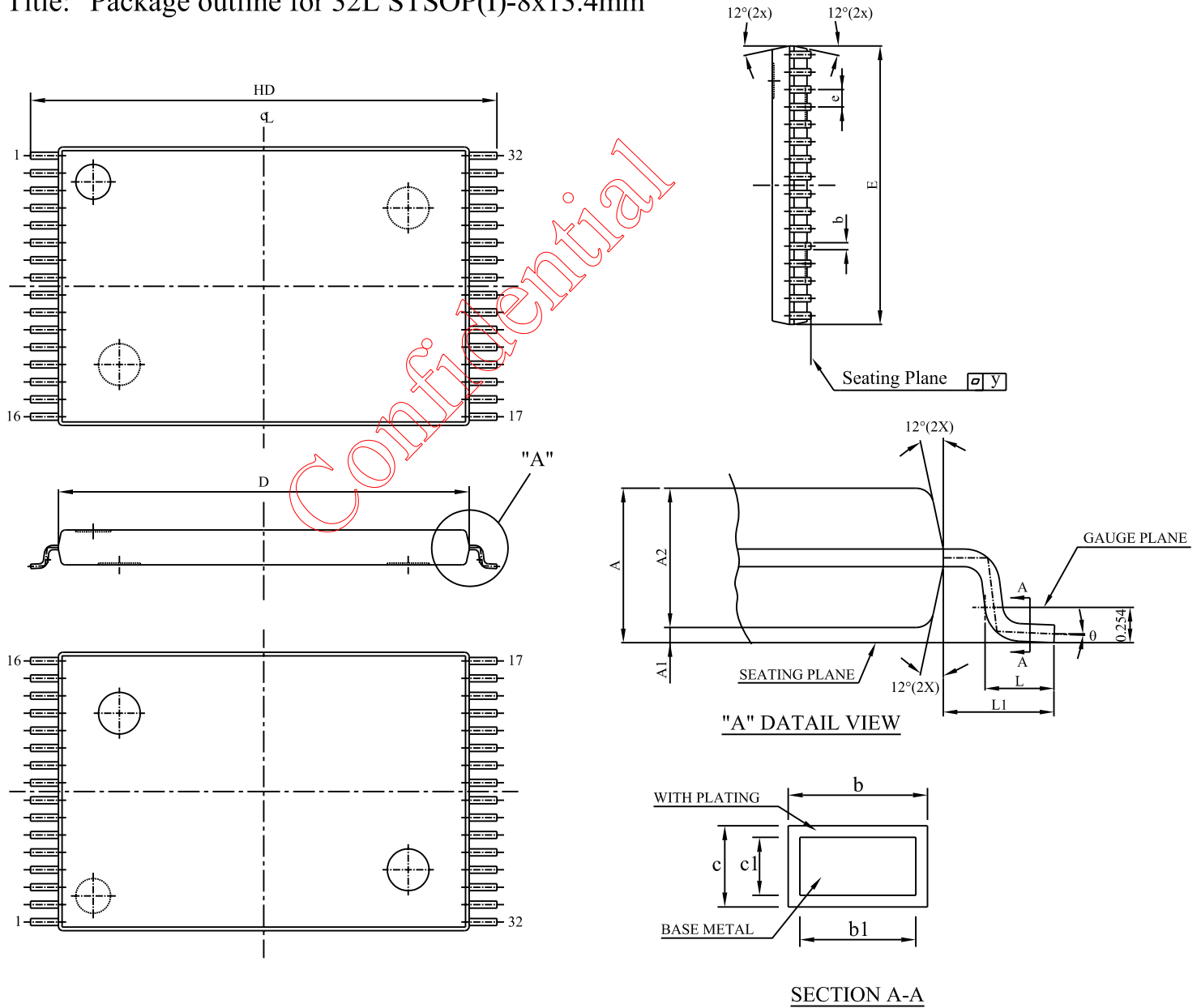

Title: Package outline for 32L STSOP(I)-8x13.4mm



Note: Plating thickness spec : 0.3 mil ~ 0.8 mil.

| SYMBOL | | A | A1 | A2 | b | b1 | c | c1 | D | E | e | HD | L | L1 | y | Θ |
|--------|------|--------|-------|-------|-------|-------|-------|-------|-------|-------|-------|-------|--------|--------|-------|----|
| UNIT | | | | | | | | | | | | | | | | |
| mm | Min. | 1.00 | 0.05 | 0.95 | 0.17 | 0.17 | 0.10 | 0.10 | 11.70 | 7.90 | 0.40 | 13.20 | 0.40 | 0.70 | - | 0° |
| | Nom. | 1.10 | 0.10 | 1.00 | 0.22 | 0.20 | - | - | 11.80 | 8.00 | 0.50 | 13.40 | 0.50 | 0.80 | - | - |
| | Max. | 1.20 | 0.15 | 1.05 | 0.27 | 0.23 | 0.21 | 0.16 | 11.90 | 8.10 | 0.60 | 13.60 | 0.70 | 0.90 | 0.1 | 8° |
| inch | Min. | 0.0393 | 0.002 | 0.037 | 0.007 | 0.007 | 0.004 | 0.004 | 0.461 | 0.311 | 0.016 | 0.520 | 0.0157 | 0.0275 | - | 0° |
| | Nom. | 0.0433 | 0.004 | 0.039 | 0.009 | 0.008 | - | - | 0.465 | 0.315 | 0.020 | 0.528 | 0.0197 | 0.0315 | - | - |
| | Max. | 0.0473 | 0.006 | 0.041 | 0.011 | 0.009 | 0.008 | 0.006 | 0.469 | 0.319 | 0.024 | 0.536 | 0.0277 | 0.0355 | 0.004 | 8° |

| DWG. NO. | ORIGINATOR | ISSUE DATE | REV. |
|------------|------------|-------------|------|
| PC600-0004 | Yuki Yeh | 03-Jan.-'08 | 1 |